

Ground-plane Antennas for 144, 222 and 440 MHz

For the FM operator living in the primary coverage area of a repeater, the ease of construction and low cost of a $\frac{1}{4}\lambda$ ground-plane antenna make it an ideal choice. Three different types of construction are detailed in **Figs 23 through 26**; the choice of construction method depends on the materials at hand and the desired style of antenna mounting.

The 144-MHz model shown in Fig 23 uses a flat piece of sheet aluminum, to which radials are connected with machine screws. A 45° bend is made in each of the radials. This bend can be made with an ordinary bench vise. An SO-239 chassis connector is mounted at the center of the aluminum plate with the threaded part of the connector facing down. The vertical portion of the antenna is made of #12 copper wire soldered directly to the center pin of the SO-239 connector.

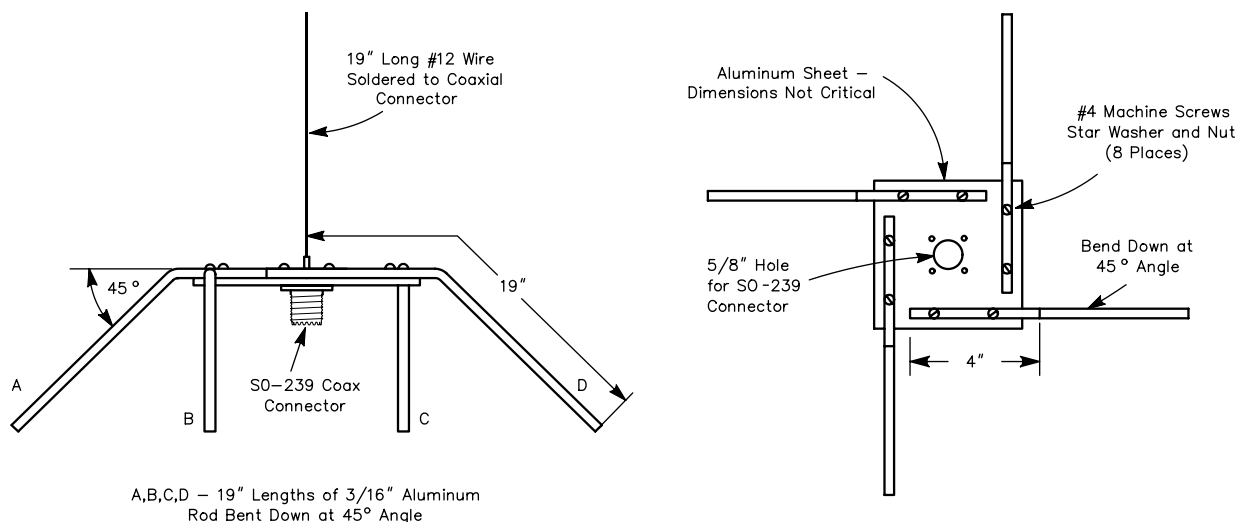

Fig 23—These drawings illustrate the dimensions for the 144-MHz ground-plane antenna.

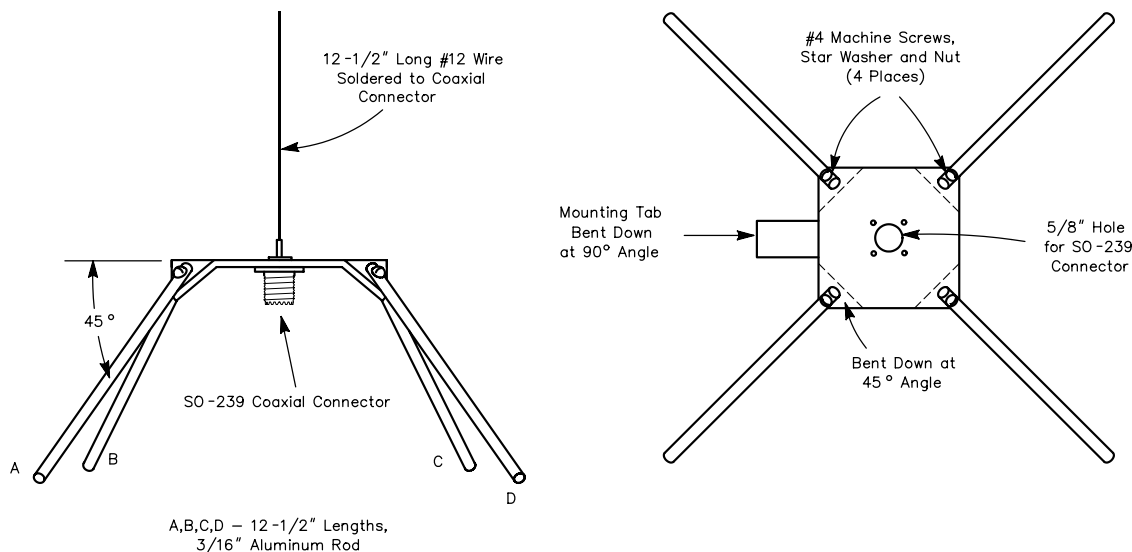

Fig 24—Dimensional information for the 222-MHz ground-plane antenna. Lengths for A, B, C and D are the total distances measured from the center of the SO-239 connector. The corners of the aluminum plate are bent down at a 45° angle rather than bending the aluminum rod as in the 144-MHz model. Either method is suitable for these antennas.

The 222-MHz version, Fig 24, uses a slightly different technique for mounting and sloping the radials. In this case the corners of the aluminum plate are bent down at a 45° angle with respect to the remainder of the plate. The four radials are held to the plate with machine screws, lock washers and nuts. A mounting tab is included in the design of this antenna as part of the aluminum base. A compression type of hose clamp could be used to secure the antenna to a mast. As with the 144-MHz version, the vertical portion of the antenna is soldered directly to the SO-239 connector.

A very simple method of construction, shown in Figs 25 and 26, requires nothing more than an SO-239 connector and some #4-40 hardware. A small loop formed at the inside end of each radial is used to attach the radial directly to the mounting holes of the coaxial connector. After the radial is fastened to the SO-239 with #4-40 hardware, a large soldering iron or propane torch is used to solder the radial and the mounting hardware to the coaxial connector. The radials are bent to a 45° angle and the vertical portion is soldered to the center pin to complete the antenna. The antenna can be mounted by passing the feed line through a mast of 3/4-inch ID plastic or aluminum tubing. A compression hose clamp can be used to secure the PL-259 connector, attached to the feed line, in the end of the mast. Dimensions for the 144, 222 and 440-MHz bands are given in Fig 25.

If these antennas are to be mounted outside it is wise to apply a small amount of RTV sealant or similar material around the areas of the center pin of the connector to prevent the entry of water into the connector and coax line.

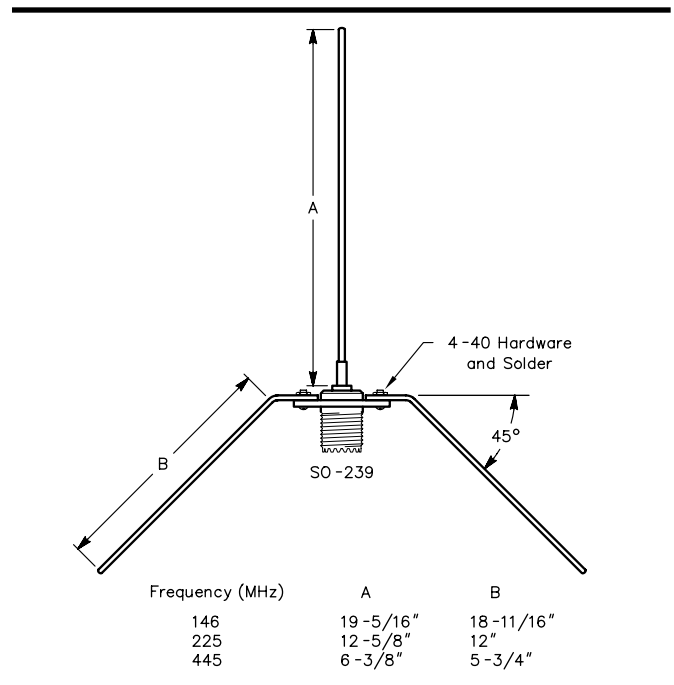

Fig 25—Simple ground-plane antenna for the 144, 222 and 440-MHz bands. The vertical element and radials are 3/32 or 1/16-inch brass welding rod. Although 3/32-inch rod is preferred for the 144-MHz antenna, #10 or #12 copper wire can also be used.

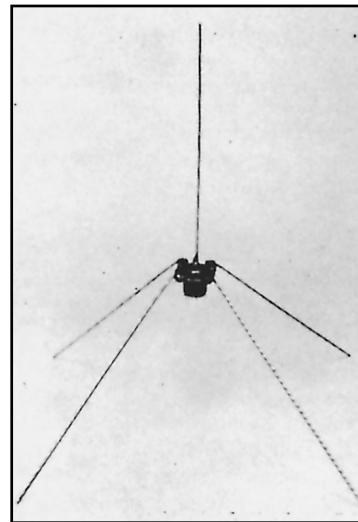

Fig 26—A 440-MHz ground-plane constructed using only an SO-239 connector, #4-40 hardware and 1/16-inch brass welding rod.